

**PILOT**  
POWER



Sand Blasting Gun  
(Gravity & Suction Feed)

**SBG 03**

Service Sheet  
& List of Spare Parts

# Spare Parts for Sand Blasting Gun SBG 03

## (Gravity & Suction Feed)

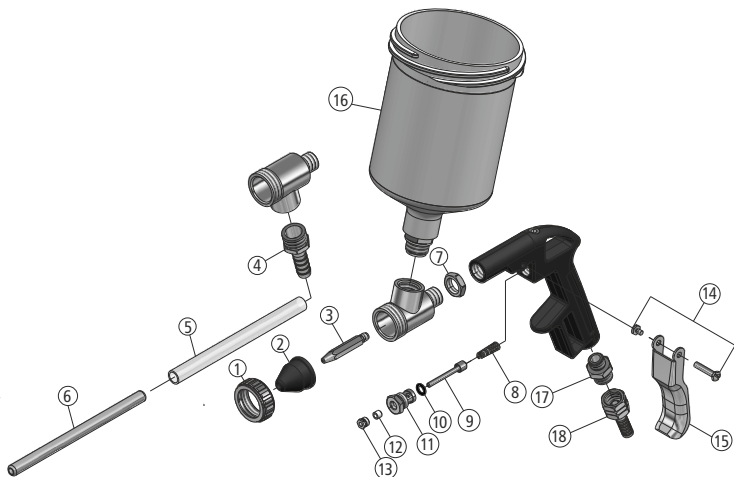

Sr. No.	Description	Code No.
	Sand Blasting Gun - SBG 03G	SBG 03000G
	Sand Blasting Gun - SBG 03S	SBG 03000S
1	Air Cap Locking Nut	SBG - 03001
2	Nozzle	SBG - 03002
3	Fluid Air Nipple	SBG - 03003
4	Connecting Nipple	SBG - 03005
5	Plastic Suction Tube	SBG - 03006
6	Metal Suction Tube	SBG - 03007
7	Head Retaining Screw Locking Nut	SBG - 03008
8	Air Valve Spring	SBG - 03011
9	Air Valve Pin	SBG - 03012

Sr. No.	Description	Code No.
10	"O" Ring	SBG - 03013
11	Air Valve Body	SBG - 03014
12	Packing Bush Set	SBG - 03015
13	Air Valve Body Packing Washer	SBG - 03016
14	Trigger Screw	SBG - 03017
15	Trigger	SBG - 03018
16	Plastic Cup 0.57 Litre Complete	SBG - 03019
17	Air Intake Connector	SBG - 03020
18	Hose Coupling	SBG - 03021

## 1. Please Read Prior to Use

- Read instructions before commissioning, especially the safety instructions.
- If while unpacking you notice any transport damages, notify your supplier and do not use the air tool.
- Take to a proper collection point and dispose the packing in an environment friendly manner.
- Keep instructions for future use.
- If you lend or sell this air tool make sure that the instructions go along with it.

## 2. Specified Conditions of Use

The Sand Blasting Gun is a handy, air-powered tool effective for the removal of rust and paint from metal and wood.

## 3. Safety Instructions

Protect yourself and your environment by taking suitable precautions so as to avoid accidents.

- Do not use the Sand Blasting Gun for any other purpose that it is not intended for.
- Wear protective clothing, especially a protection hood.
- The Sand Blasting Gun should not be used in hazardous locations.
- Do not use combustible blast media.
- Keep air tools out of children's reach.
- Never direct the Sand Blasting Gun towards/against other human beings or animals.
- Connect to pressurized air supply only with a hose coupling.
- Working pressure must be set by means of a filter/pressure regulator.
- Use only pressurized air as energy source, avoid using gases.
- Disconnect from air source before servicing.
- Please take adequate precautions to prevent any possible damage/nuisance from generated dust.
- Make sure that the blast media is collected for an environment friendly disposal.
- Do not use glass sand so as to avoid the risk of silicosis.
- Never open the blast media tank by force.

## 4. Initial Operation

1. Blasting media is fed to the gravity cup of SBG 03G which is to be tightened clockwise and for SBG 03 S the blasting media is fed to the tank wherein the material is syphoned from it for blasting.
2. Connect Sand Blasting Gun to a suitable compressor or pressurized air source. Use a flexible air hose of 9 mm inner diameter and a max. Length of 10 m, fitted with a hose coupling.
3. Start operation by pulling the gun's trigger.
4. The blast media is now taken in and blasted onto the selected surface.
5. The distance of the nozzle to the object to be sandblasted should not be more than 20 cm.

## 5. Care and Maintenance

Observance of the maintenance instructions given here will ensure a long service life and trouble-free operation of this quality product. Ensure that the blast media is fully dry and not too coarse grained. We recommend the use of silicosis safe blast media (ground blast furnace slag) of 0.2 - 0.8 mm grain

size. Always disconnect from air supply when servicing. For a continuous trouble-free operation the Sand Blasting Gun must be thoroughly cleaned after each use. Periodically apply a few drops of oil to the valve stem and trigger pin. Store your air tools in dry rooms only.

## 6. Technical Specifications

	SBG 03G	SBG 03S
Air consumption	Approx 220 l/min	Approx 220 l/min
Working pressure	Max.7.0 bar	Max. 7.0 bar
Blasting nozzle	Ø 4 mm	Ø 4 mm
Blast media (grain size)	0.2 - 0.8 mm	0.2 - 0.8 mm
Weight	421 gms.	481 gms.
Recommend inner air hose diameter	9 mm	9 mm
Pressurized air required	clean and oil-free	
Recommended working pressure	Max. working pressure set at regulator or filter/pressure regulator max. 7 bar.	

Manufactured by:

### Manik Radiators Pvt. Ltd.

Shed No.3, Plot No. 126/1 2B, Village Horale, Khopoli Pen Road,  
Khalapur, Raigad 410203, Maharashtra, INDIA Tel.: +91 22 660 47 000  
E-mail: info@pilotindia.com • www.pilotindia.com