

**PILOT**  
POWER

**FG 03**



Service Sheet &  
List of Spare Parts

## Spare Parts for Foundry Gun FG 03

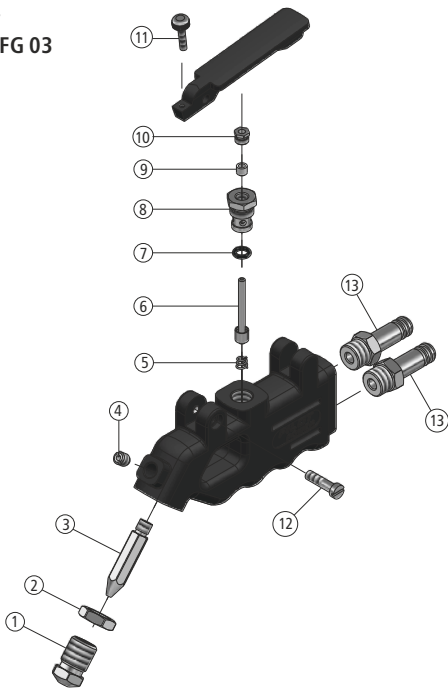

Sr. No.	Description	Code No.
	<b>Foundry Gun - FG 03</b>	<b>FG - 03000</b>
1	Nozzle	FG - 03001
2	Nozzle Locking Nut	FG - 03002
3	Injector Tube	FG - 03003
4	Liquid Throttling Bush	FG - 03004
5	Air Valve Spring	FG - 03006
6	Air Valve Pin	FG - 03007
7	"O" Ring	FG - 03008

Sr. No.	Description	Code No.
8	Air Valve Body	FG - 03009
9	Packing Bush Set	FG - 03010
	Air Valve Packing Box Washer	FG - 03011
11	Trigger Adj. Screw	FG - 03013
12	Trigger Screw	FG - 03014
13	Hose Connection	FG - 03015

## 1. Please Read Prior to Use

- Read instructions before commissioning, especially the safety instructions.
  - If while unpacking you notice any transport damages, notify your supplier and do not use the air tool.
  - Take to a proper collection point
- and dispose the packing in an environment friendly manner.
  - Keep instructions for future use.
  - If you lend or sell this air tool make sure that the instructions go along with it.

## 2. Specified Conditions of Use

- Used in foundries and die moulds manufacturing companies.
  - Used as an air gun for blowing out moulds and patterns.
  - Used as a spray gun for applying foundry liquid dressings (mould
- coats & terracoat etc) and partings (separol etc).
  - Used as an agitator for dressings that tend to settle out and spraying mould and core washes of a fairly thick consistency.

## 3. Safety Instructions

Protect yourself and your environment by taking suitable precautions so as to avoid accidents.

- Do not use Foundry Gun for any other purpose that it is not intended for.
  - Ensure good ventilation of the work area.
  - Wear protective clothing, especially, safety glasses and gloves
  - Do not exceed the maximum working pressure .
  - Never direct the Foundry Gun against other human beings or animals.
- Keep air tools out of children's reach.
  - Connect to pressurized air supply only with a hose coupling.
  - Working pressure must be set by means of a filter/pressure regulator.
  - Use only pressurized air as energy source, avoid using gases.
  - Disconnect from air source before servicing.

## 4. Initial Operation

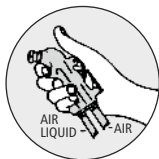

1. **For air blast only:** Just press the trigger as shown in figure.

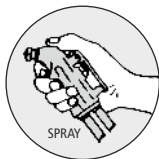

2. **For spraying:** Press the trigger with the base of the thumb and cover orifice with the ball of thumb. Regulate the density of the spray with the thumb still covering orifice by loosening locking nut and turning hexagon rim until the required density is reached, when the locking nut is tightened again (diagram) spray.

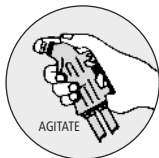

3. **For agitating:** Cover nozzle opening with index finger and operate as if spraying agitation can be controlled by variation of pressure on trigger. As supplied, the PILOT POWER FG-03 triple action gun is ideal for spraying mould and core washes of a fairly thick consistency (diagram) AGITATE.

## 5. Technical Specifications

Air consumption	Approx 85 l/min
Working pressure	3-4 kg/cm <sup>2</sup>
Nozzle dia	Ø 4 mm
Weight	310 gms.

Manufactured by:

**Manik Radiators Pvt. Ltd.**

Shed No.3, Plot No. 126/1 2B, Village Horale, Khopoli Pen Road,  
Khalapur, Raigad 410203, Maharashtra, INDIA Tel.: +91 22 660 47 000  
E-mail: info@pilotindia.com • www.pilotindia.com